



PROFESSIONAL DIRECT DRIVE TURNTABLE

**PDX-2300**

**OWNER'S MANUAL**

VESTAX CORPORATION  
1-18-16 Wakabayashi, Setagaya-ku, Tokyo 154-0023 Japan  
Phone : 03-3412-7011 Fax : 03-3412-7013  
E-mail : info@vestax.com  
www.vestax.com

VESTAX Europe Ltd.  
Unit 5, Riverwey Industrial Park  
Alton, Hampshire GU 34 2QL, England.  
Phone : (0)1420-83000 Fax : (0)1420-80040  
www.vestax.co.uk

# CONGRATULATION

Thank you for purchasing the Vestax PDX-2300, Professional Direct Drive Turntable. Please read this owner's manual carefully, so that you will fully understand all of the special features and enjoy the full use of this product.

## CONTENTS

FEATURES .....	3
NOTES.....	3
A.S.T.S (Anti Skipping Tone-arm System) .....	4
PARTS .....	5
BEFORE USE .....	5
ASSEMBLY AND SET-UP .....	6
INSTALLATION AND CONNECTION .....	8
ADJUSTMENT(S) .....	9
OPERATION.....	10
SPECIFICATION.....	14

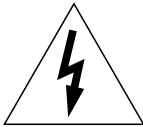

### CAUTION

RISK OF ELECTRIC SHOCK DO NOT OPEN



**CAUTION : TO REDUCE THE RISK OF ELECTRIC SHOCK  
DO NOT REMOVE COVER (OR BACK)  
NO USER-SERVICEABLE PARTS INSIDE  
REFER SERVICING TO QUALIFIED SERVICE PERSONNEL**

The lightning flash with arrowhead, symbol within an equilateral triangle, is intended to alert the user to the presence of uninsulated "dangerous voltage" within the product's enclosure that may be of sufficient magnitude to constitute a risk of electric shock to persons.

The exclamation point within an equilateral triangle is intended to alert the user to the presence of important operating and maintenance (servicing) instructions in the literature accompanying the appliance.

**TO REDUCE THE RISK OF FIRE OR ELECTRIC SHOCK, DO NOT EXPOSE THIS APPLIANCE TO RAIN OR MOISTURE.**

**CAUTION : TO PREVENT ELECTRIC SHOCK, MATCH BLADE OF PLUG TO WIDE SLOT, FULLY INSERT**

**ATTENTION : POUR EVITER LES CHOCES ELECTRIQUES, INTRODUIRE LA LAME LA PLUS LARGE DE LA FICHE DANS LA BORNE CORRESPONDANTE DE LA PRISE ET POUSSER JUSQU' AU FOND**

# IMPORTANT SAFEGURDS

## READ BEFORE OPERATING EQUIPMENT

**This product was designed and manufactured to meet strict quality and safety standards. There are, however, some installation and operation precautions which you should be particularly aware of.**

1. Read instructions-All the safety and operating instructions should be read before the appliance is operated.
2. Retain instructions-The safety and operating instructions should be retained for future reference.
3. Heed Warnings-All warnings on the appliance and in the operating instructions should be adhered to.
4. Follow Instructions-All operating and use instructions should be followed.
5. Cleaning-Unplug this product from the wall outlet before cleaning. Do not use liquid cleaners or aerosol cleaners. Use a damp cloth for cleaning.
6. Attachments-Do not use attachments not recommended by the product manufacturer as they may cause hazards.
7. Water and Moisture-Do not use this product near water-for example, near a bath tub, wash bowl, kitchen sink, or laundry tub, in a wet basement, or near a swimming pool, and the like.
8. Accessories-Do not place this product on an unstable cart, stand, tripod, or table. The product may fall, causing serious injury to a child or adult, and serious damage to the appliance. Use only with a cart, stand, tripod, bracket, or table recommended by the manufacturer, or sold with product. Any mounting of the appliance should follow the manufacturer's instructions, and should use a mounting accessory recommended by the manufacturer.
9. Ventilation-Slots and openings in the cabinet are provided for ventilation and to ensure reliable operation of the product and to protect it from overheating, and these openings must not be blocked or covered. The openings should never be blocked by placing the product on a bed, sofa, rug, or other similar surface. This product should never be placed near or over a radiator or heat register. This product should not be placed in a built-in installation such as a bookcase or rack unless proper ventilation is provided or the manufacturer's instructions have been adhered to.
10. Power sources-This product should be operated only from the type of power source indicated on the marking label. If you are not sure of the type of power supply to your home, consult your appliance dealer or local power company.
11. Grounding or Polarization-This product is equipped with a polarized alternating-current line plug (a plug having one blade wider than the other). This plug will fit into the power outlet only one way. This is safety feature. If you are unable to insert the plug fully into the outlet, try reversing the plug. If this should still fail to fit, contact your electrician to replace your obsolete outlet. Do not defeat the safety purpose of the polarized plug.
12. Power-Cord Protection-Power supply cords should be routed so that they are not likely to be walked on or pinched by items placed upon or against them, paying particular attention to cords at plugs, convenience receptacles, and the point where they exit from the appliance.
13. Protective Attachment Plug-The appliance is equipped with an attachment plug having overload protection. This is a safety feature. See Instruction Manual for replacement or resetting of protective device. If replacement of the plug is required, be sure the service technician has used a replacement plug specified by the manufacturer that has the same overload protection as the original plug.
14. Lightning-For added protection for this product during lightning storm, or when it is left unattended and unused for long periods of time, unplug it from the wall outlet. This will prevent damage to the product due to lightning and power-line surges.
15. Overloading-Do not overload wall outlets and extension cords as this can result in a risk of fire or electric shock.
16. Object and Liquid Entry-Never push objects of any kind into this product through openings as they may touch dangerous voltage points or short-out parts that could result in a fire or electric shock. Never spill liquid of any kind on the product.
17. Servicing-Do not attempt to service product yourself as opening or removing covers may expose you to dangerous voltage or other hazards. Refer all servicing to qualified personnel.
18. Damage Requiring Service-Unplug this product from the wall outlet and refer servicing to qualified service personnel under the following conditions:
  - a. When the power-supply cord or plug is damage.
  - b. If liquid has been spilled or objects have fallen into the product.
  - c. If the product has been exposed to rain or water.
  - d. If the product dose not operate normally by following the operating instructions. Adjust only those controls that are covered by the operating instructions as an improper adjustment of other, controls may result in damage and will often require extensive work by a qualified technician to restore the product to its normal operation.
  - e. If the product has been dropped or cabinet has been damaged.
  - f. When the product exhibits a distinct change in performance-this indicates need for service.
19. Replacement Parts-When replacement parts are required, be sure the service technician has used replacement parts specified by the manufacturer or have the same characteristics as the original parts. Unauthorized substitutions may result in fire, electric shock or other hazards.
20. Safety Check-Upon completion of any service or repairs to product, ask the service technician to perform safety checks to determine that the product is in proper operating condition.
21. Carts and Stands-The appliance should be used only with a cart stand that is recommended by manufacturer.
22. An appliance and cart combination should be moved with care. Quick stops, excessive force, and uneven surfaces may cause the appliance and cart combination to overturn.



# FEATURES

---

- Advanced analogue turntable.
- Enhanced pitch control. Fast and accurate beat matching adjustment with a 100mm +/-10% fine pitch fader. Ultra pitch control with a +/-50% control fader. Combined the total amount you can adjust the pitch by is a huge +/-60%pitch. Furthermore, with the pitch bend joystick, you can quickly push or pull the pitch for smooth mixes or dynamic effects.
- Digital Pitch Display. A large display, showing the current pitch setting, allows you to accurately set the pitch or when needed to, make adjustments perfectly.
- Strong DC motor with 2.7kg torque allowing for super high-speed start times.
- Adjustable start and break speeds (within 1/4 RPM).
- A.S.T.S - anti skipping tone arm system - the most reliable and strongest tone arm system available for professional turntables of this kind. This system when combined with Tracking Hold (TH) technology can reduce skipping and needle vibration by up to 90%.
- Adjustable tone arm height and weight.
- Start and brake speeds can be adjusted and pre-set for improved performance.
- Reverse play is possible with the quick easy one touch reverse play button.
- The futuristic body design of the PDX-2000 and PDX-2300 is made of a super high density moulded plastic that provides not only the best possible acoustic sounds but also reduces feedback.

# NOTES

---

- Ensure that the power to any mixer or amplifier that the turntable is connected to is turned OFF before attaching or detaching the head shell. Failing to do so may damage your mixer, amplifier or speakers.
- Whilst the platter is detached **DO NOT TURN ON THE TURNTABLE.**
- When you have finished using the turntable please ensure that the tone arm is secured with the tone arm clamp. If the unit is not to be used for an extended period it is also sensible to ensure that the stylus tip is protected. Most conventional cartridges come with an attached stylus protector.
- Dust, dirt and other surface grime should be removed from the unit, the stylus tip and any records to be played on the unit. Take care so as to avoid damage. We suggest using a dry soft cloth.
- Please take care when transporting this unit, or packing for storage. It is best to use the original packaging materials provided in either case. Should this not be possible, then please take care to wrap the platter and the unit separately, and to ensure that the entire unit is kept in a dry place out of direct sunlight. Before wrapping please remove the stylus and to avoid damage to the tone arm, please set the tone arm in the tone arm clamp and apply a reasonable amount of tape to ensure that it does not move.
- To avoid feedback or hum, locate the speakers and the turntable in a suitable position. Feedback is often caused by the vibration of speakers, which in turn affects sensitive cartridges, producing a poor sound. If such occurs, relocate the turntable or speakers so as to be as far apart from each other as possible. Hum is often caused by nearby appliances that use a transformer or thermostat. Relocating the units again as far away as possible to the source will help with this problem. Hum may also be produced if the grounding wire is not securely fastened to the mixer or amplifier.

# A.S.T.S (Anti Skipping Tone-arm System)

The A.S.T.S (Anti Skipping Tone-arm System) was years in trial and development. Initially the quest was to improve on the tracing of tone arms available at the time, but soon the quest mutated into designing a completely new tone arm and hold system. The result of this laborious task has enhanced the turntables potential immensely and is now incorporated into all Vestax professional level turntables. The system breaks with ill founded traditional tone arm logic in order to achieve a high level of non skipping performance, especially during hard play (scratch). Essentially this system focuses on two very separate, yet very important inventions. One is a short straight arm and the other is the way in which the arm is balanced, both vertically and horizontally.

- TH (Tracing hold) Balance System. This system allows for both vertical and horizontal movement, which helps the balance of the tone arm. When combined with a short straight tone arm the best stability ever is provided for the needle, which in turn allows for hard play.
- The tone arm, both straight and short, is made up of two parts - an inner and an outer tube. The inner tube, brass, is housed within an outer tube of aluminum, which reduces the effects of howling and also provides a more sensitive pick up. Compared with other tone arms on the market, the A.S.T.S tone arm reduces howling by approximately 50% more.

NORMAL TYPE TONE-ARM

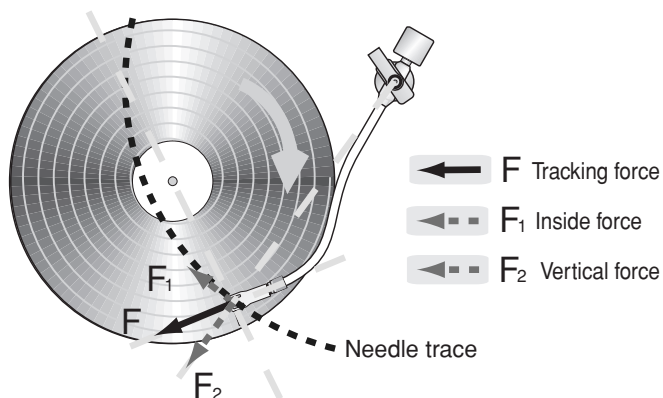

The tracking force (frictional force) generated between the stylus and the record disc makes the inside force.

A. S. T. S

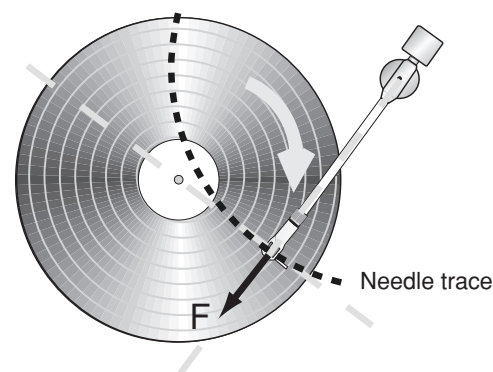

The inside force is minimized.

# PARTS

## Front

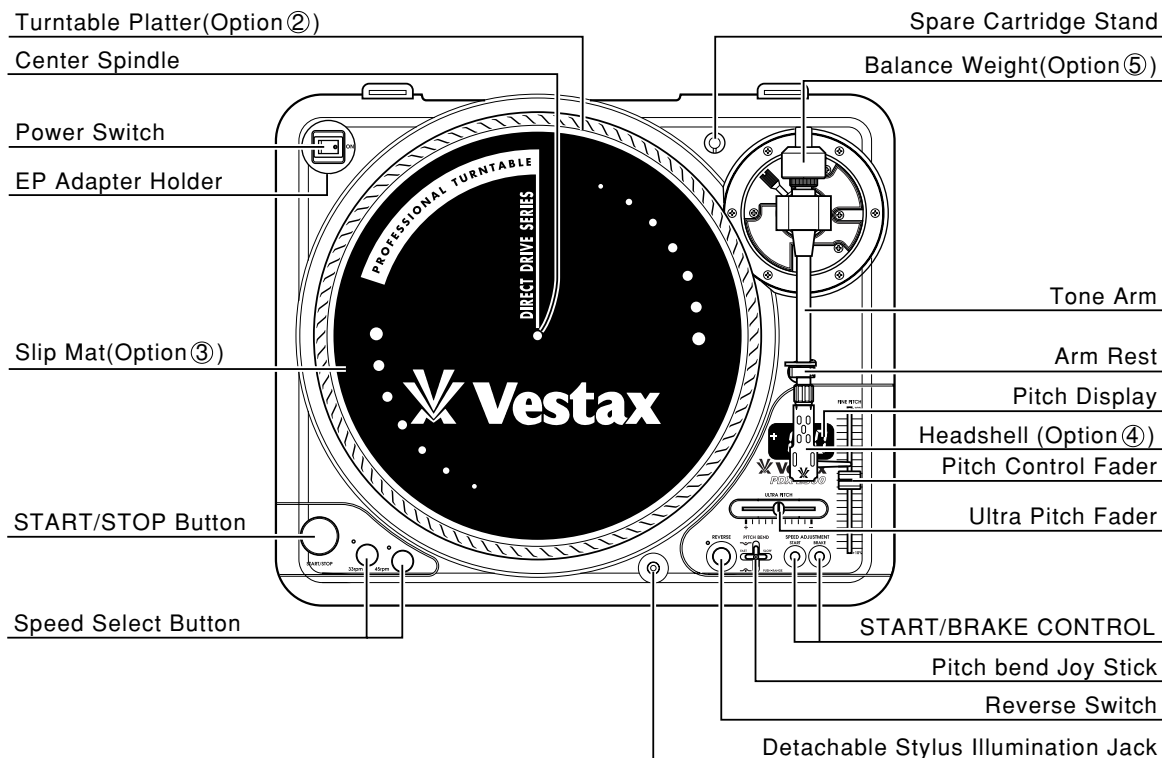

## Rear

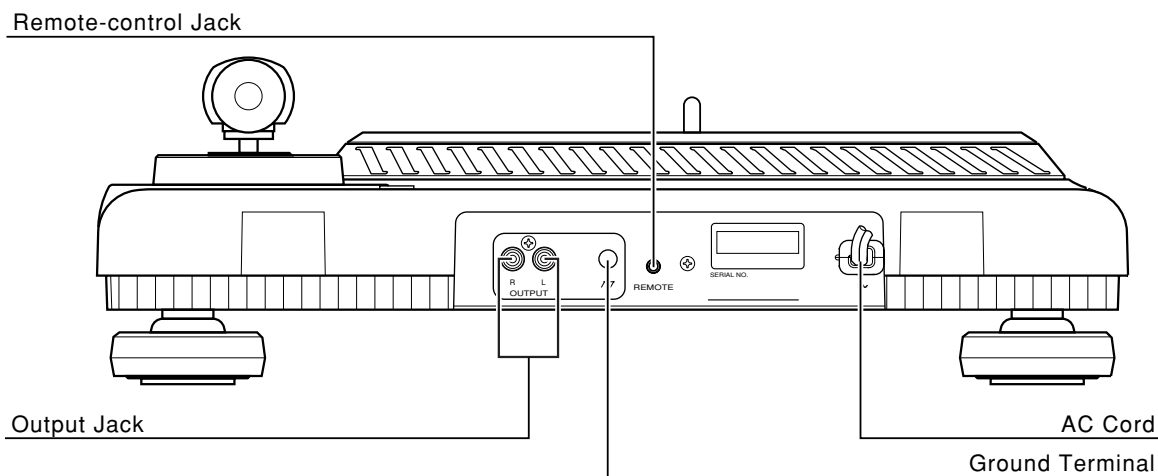

# BEFORE USE

## Parts and accessories

Before use, please check that you have all parts.

- ① Main unit
- ② Platter
- ③ Split mat
- ④ Head shell
- ⑤ Balance weight

- Accessories accompanying this booklet.
- ⑥ Shell weight
- ⑦ RCA cable
- ⑧ GND cable
- ⑨ EP adopter
- ⑩ Platter screws
- ⑪ Screw driver for platter screws
- ⑫ Owner's manual

# ASSEMBLY AND SET-UP

## Turntable Assembly

- ① Place the platter on the center spindle. The platter will adjust itself to best fit over the spindle.
  - ② Adjust the positioning of the platter so that the screw holes line up perfectly.
  - ③ Screw and tighten accordingly.
  - ④ Place the slip mat on the platter.
- \*\*\* Care should be taken to avoid dropping either/both, the platter or the cabinet.

### NOTE

- If the player is operated without fixing the screws, the platter may not rotate properly.
- Do not plug in to a power outlet until this unit is fully assembled and adjusted.

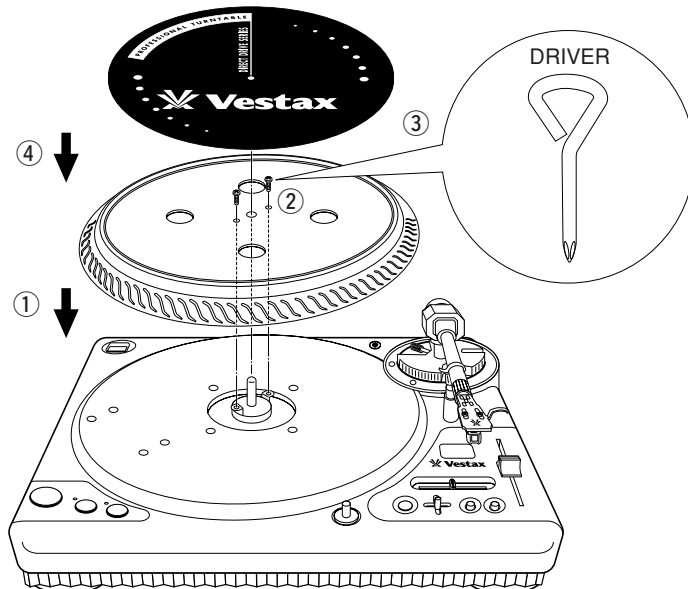

## Installing the balance Weight

- ① From the backend of the tone arm (towards the rear panel) place the balance weight onto the shaft and turn counter clockwise. (Refer to the illustration)

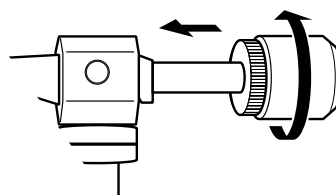

## Slip mat

- ① Place the slip mat on the platter. Then place a record on top of the slip mat. The slip mat is essentially used to give you better control over the spinning of your record. That is, with the slip mat in place you are able to stop, pull or push the record without affecting the rotation of the platter.



Top : Record disc side (Printed side)  
Bottom : Slip surface side

(The slip mat included with this unit may differ from illustrations in this user guide or in other publications.)

## Cartridge Installation

- ① Make sure that you follow the instructions included with your cartridge.
- ② Connect the lead wires to the respective terminals. Industry standard cartridges come with color-coded wires. Make sure that you match these colors correctly.

Red (R+) → Right Channel+    Green (R-) → Right Channel -  
 White (L-) → Left Channel+    Blue (L-) → Left Channel -

### NOTE

If using a light weight cartridge, we suggest the use of the shell weight enclosed.

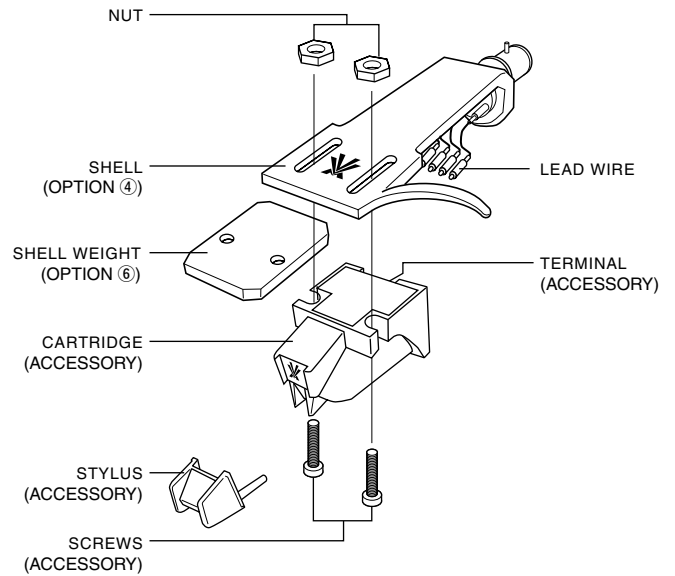

- ③ The overhang of your cartridge needs to be adjusted to best suit the A.S.T.S tone arm. For best tracking and stylus pressure a distance of 50mm (as shown) should be set.

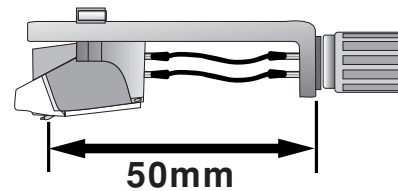

### NOTE

To avoid premature damage to the stylus take care to avoid touching it during any adjustment(s).

- ④ Insert the head shell into the front part of the tone arm. Turn the locking ring in the direction shown below until the head shell is firmly fixed in place.

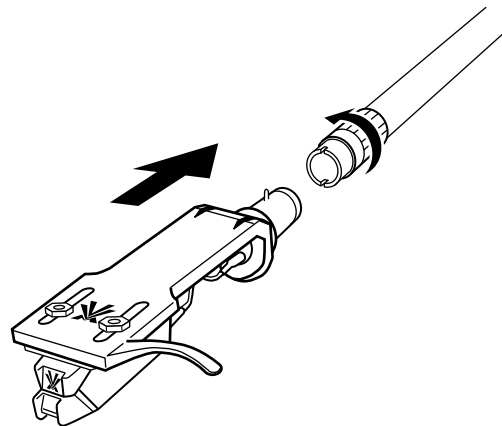

# INSTALLATION AND CONNECTION

## Power Connection

Plug in the unit to a power outlet.

### NOTE

This unit has been manufactured to strict quality and safety standards. PLEASE ENSURE that you use the correct power supply as shown on the rear panel of this device. FAILURE to do so may result in shock and/or serious damage to this unit and/or users.

## Player Installation

- Do not expose this unit to direct sunlight, or install in an area that is typically humid and/or damp.
- Place this unit on a stable, horizontal surface in order to limit vibration and poor tracking/action of the tone arm.
- Locate this unit at a suitable distance from any speakers so as to avoid feedback.
- Interference may result from close proximity of an AM/FM tuner.

## Connecting Phono terminal

With the RCA cable (accessory 7) and the GND cable (accessory 8), connect the output terminals and the GND terminal on the PDX-2300 rear panel, and the phono input terminals to the respective terminals on your amplifier/mixer.

### NOTE

Ensure that the GND (ground) terminal is firmly connected to a mixer or amplifier. If the GND terminal is not correctly connected HUM may persist.

### Example

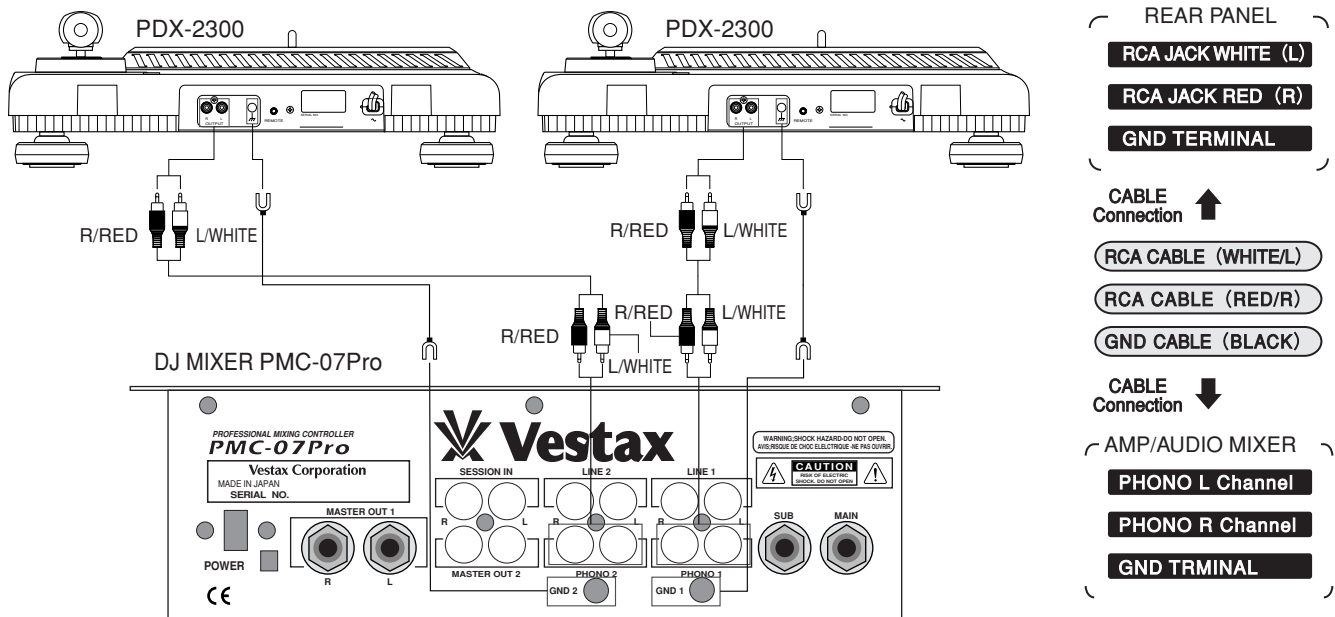

# ADJUSTMENT(S)

## Adjustment of Horizontal Zero Balance

- ① Carefully release the tone arm from the tone arm clamp.
- ② Turn the balance weight clockwise or anti-clockwise until balanced horizontally.

### NOTE

When adjusting the horizontal balance, take care not to touch the stylus.

- ③ Return the tone arm to resting position.
- ④ After adjusting the horizontal balance, set the balance weight rotating only the counter ring to align with by the "0" weight setting to the center line of the arm axis.

### NOTE

If the balance weight is moved, readjust the horizontal balance again.

- ⑤ Turn the balance weight in the direction shown to adjust the stylus pressure (weight setting will depend on your stylus). When you turn the balance weight, the counter ring moves displaying the weight setting (0-5).

### NOTE

If you put too much pressure on the stylus, it can cause the stylus to jump/skip during scratch play and will shorten the stylus's life.

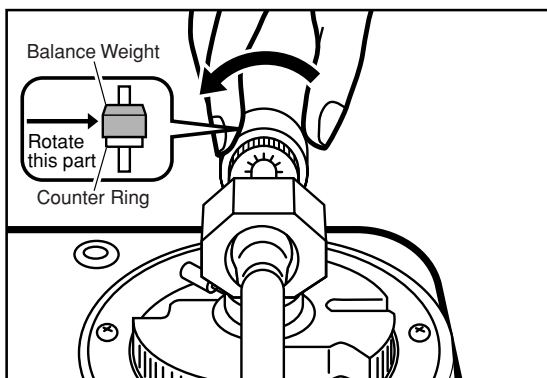
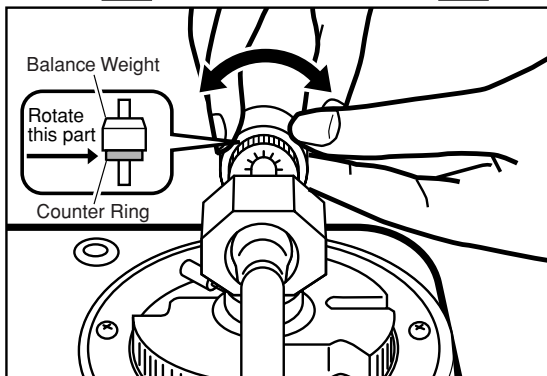
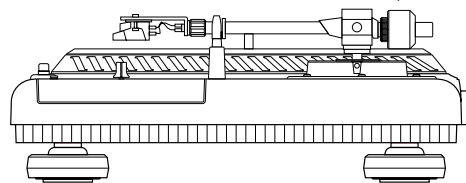
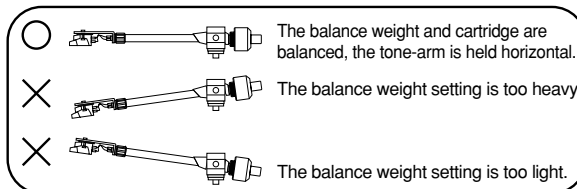
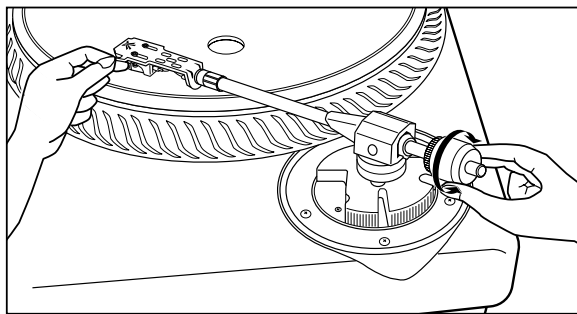

## Tone arm height adjustment

A Tone arm height adjustment may be necessary for some cartridge types. The height can be adjusted up to 9mm by rotating the arm height adjustment screw.

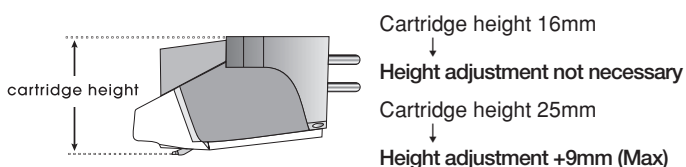

### NOTE

Be sure to tighten the arm height adjustment screw well. The stylus may jump/skip if the height setting is not secured.

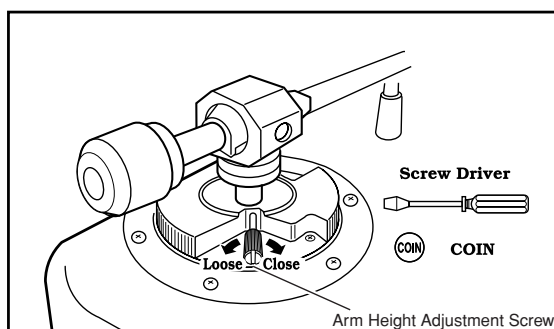

# OPERATION

- ① Place a record on the slip mat.
- ② Switch on the unit using the Power on/off switch located on the rear panel.
- ③ Remove the stylus protector if applicable.

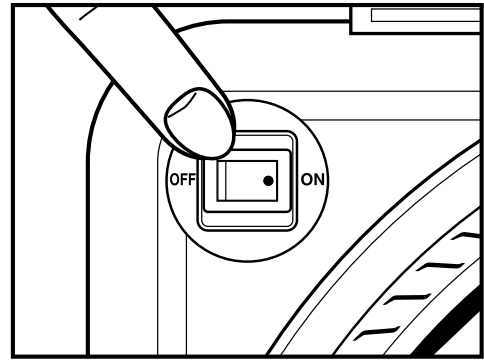

- ④ Start the platter spinning with the START/STOP button.

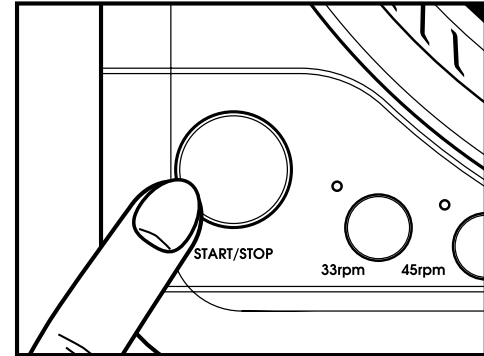

- ⑤ Position the tone arm over the record and gently lower to begin playback.
- ⑥ Set the playing speed to either 33 1/3 or 45 RPM.

## NOTE

When turned on this unit is set to play at 33 1/3 RPM. To adjust to a 45RPM speed setting, press the 45 RPM button. This unit does not use a cue lever system for speed setting(s).

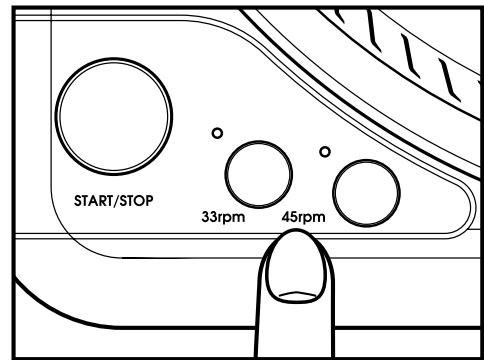

- ⑦ Move the tone arm to the resting position and secure using the tone arm clamp.
- ⑧ Push the START/STOP button to stop the platter from spinning.
- ⑨ Turn the unit off.

## NOTE

If the power switch is turned off without pressing the START/STOP button, the electric brake will not function.

## Remote Control

The START/STOP functions of the PDX-2300 can be controlled externally with equipment such as a foot switch peddle. An input jack is provided for this remote control on the rear panel of this unit.

## Playing EP records

Fit the EP adapter over the center spindle and follow the same playing instructions as written above.

## Stylus light (Detachable mini light)

A detachable stylus light is available for this unit as an optional extra.

## Advanced Pitch Control Features

The PDX-2300 features advanced digital pitch control features. Through three different controls you are able to adjust the playing pitch by up to +/-60%.

### ① PITCH BEND & ULTRA SHIFT

Using the pitch bend joystick will allow you to quickly pull or push the playing pitch of this unit. To pull means to slow down, push means to speed up. Pushing the joystick towards the tone arm will result in you being able to pull (minus) the playing pitch. Pushing the joystick in the opposite direction will result in you being able to push (positive) the playing pitch. It is possible to set the increment of pitch adjustment or the pitch span to 1,2,3, & 6%. The basic pitch span setting is 2%. To change the pitch span setting press the joystick down. Pushing the joystick down once will set the span to 3%, twice 6%, three times 1% and a fourth time will set it back to 2%. You can also ultra shift the pitch by +/-50% by pushing the joystick left or right. A movement to the left will speed up the pitch momentarily whilst a push to the right will slow down the pitch momentarily. This momentary ultra shift is always set to +/-50%.

#### NOTE

When the power is turned on, pitch bend is set at  $\pm 2\%$ .

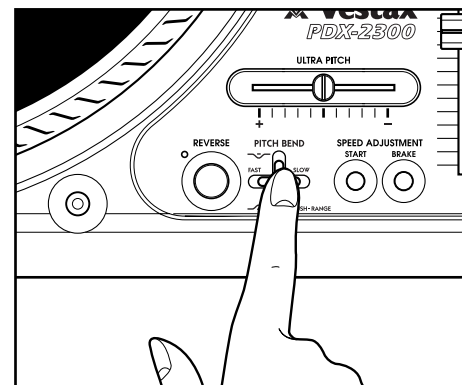
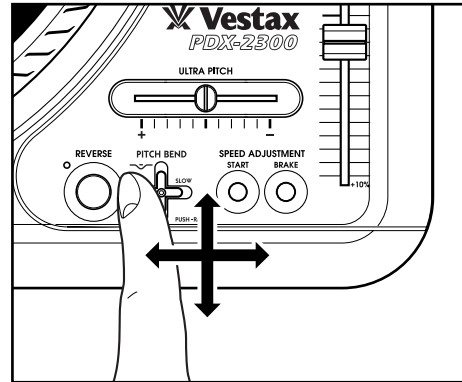

#### Display

Every time the stick controller is pressed, the display changes as shown below.

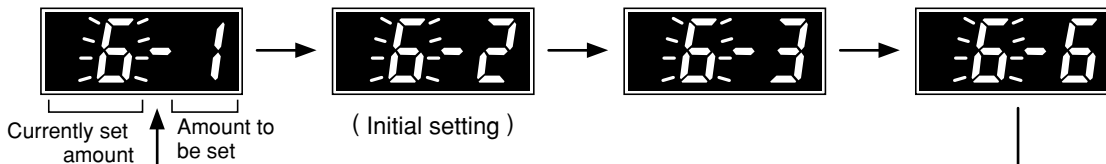

### ② FINE PITCH CONTROL

The PDX-2300 has two pitch control faders. The larger, 100mm fader control is for fine pitch adjustment. With the fine pitch fader you are able to make accurate adjustments up to +/-10%.

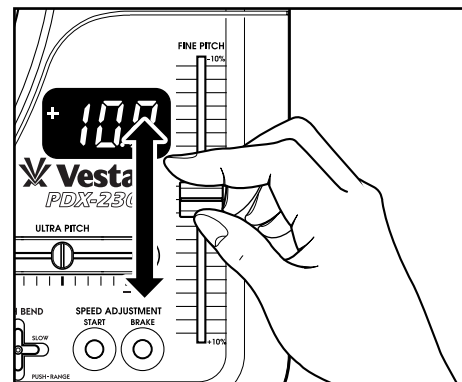

### ③ ULTRA PITCH FADER

Using the ultra pitch fader will allow you to make dramatic and accurate pitch adjustments up to +/-50%.

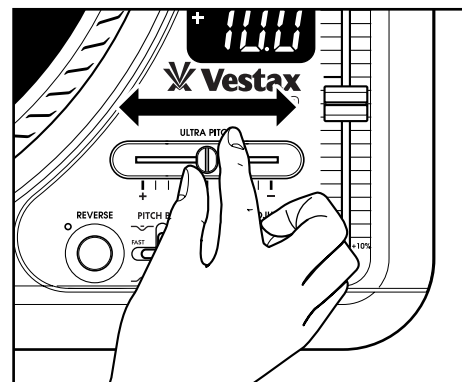

## Start Speed

You can adjust the starting speed of the platter by adjusting the SPEED ADJUSTMENT 'START' dial. A clockwise rotation slows down the starting speed whilst an anti clockwise rotation will speed it up. At its maximum setting after pressing the START button, the PDX-2300 has an amazingly quick start up (to full speed) of around 0.5 seconds.

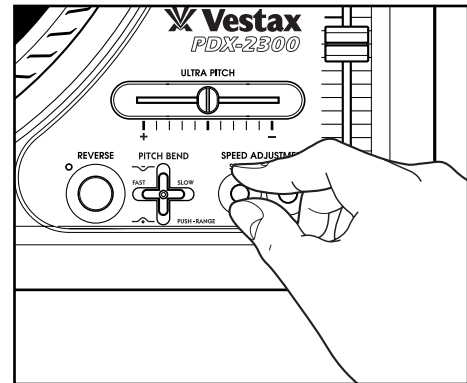

## Brake Speed

As well as being able to change the start speed, you can alter the speed at which the platter brakes or slows down. A clockwise rotation of this dial gives a slow brake speed whilst an anti clockwise rotation produces the fastest brake speed possible. Again, the powerful motor (and therefore platter speed) of the PDX-2300 is far beyond that of its closest competitor.

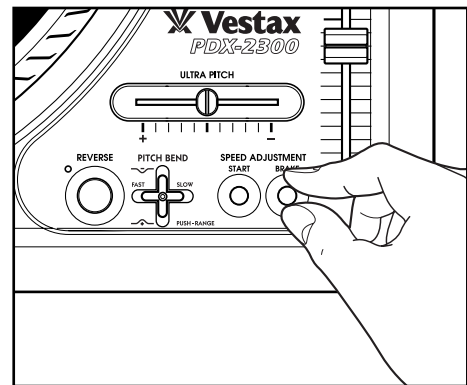

## Reverse Play

When pushed, this button will instantly reverse the playing direction of the platter. In reverse mode, an indicator LED will be on. When the unit is first turned on, the platter is set to spin in the normal forward direction.

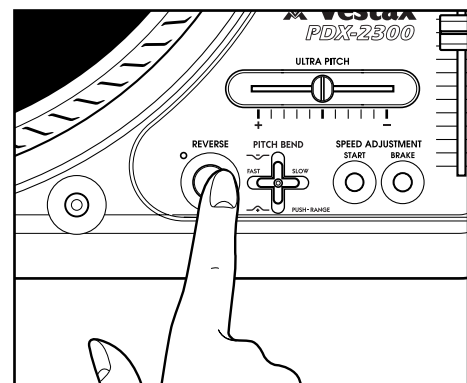



## SPECIFICATION

TURNTABLE	MOTOR START UP TIME STARTING TORQUE BRAKING SYSTEM RAMBLE ( S/N RATIO ) SPEED FINE PITCH ULTRA PITCH PITCH BEND WOW & FLUTTER	DIRECT DRIVE 0.5sec ( 33 1/3 rpm ) 70° 2.7 kg · cm ELECTRONIC BRAKE 78dB ( IEC 98 WTD ) 33 1/3 rpm, 45rpm ± 10% ( 100mm FADER ) ± 50% ( 45mm FADER ) ± 1,2,3,6 % ( Front ⇄ Rear ) ± 50 % ( Right ⇄ Left ) 0.07% W.R.M.S.
ARM	TYPE BALANCE TONE-ARM HEIGHT STYLUS PRESSURE	ANTI SKIPPING TONE-ARM SYSTEM. TRACING HOLD BALANCE SYSTEM ADJUSTMENT RANGE 9mm (MAXIMUM) ADJUSTMENT RANGE 0 ~ 7.0g
	LIGHT ( OPTIONAL ) REMOTE DIMENSION WEIGHT POWER	DETOUCHABLE MINI LIGHT DC12volt 100mA MOMENTARY START ( MINI JACK ) ( W ) 454mm X ( H ) 162mm X ( D ) 365mm 9.5kg AC120V or AC230V 50W